

No	2	Date	31.05.2016
Tech.	SM	Mod.	19.10.2016
Ech.	1 : 2	Mod.	
Ech.	A 4	Mod.	

Article Cadre rénovation

CAD
2017

Objet

Fenêtre bois à l'ancienne

POS.:

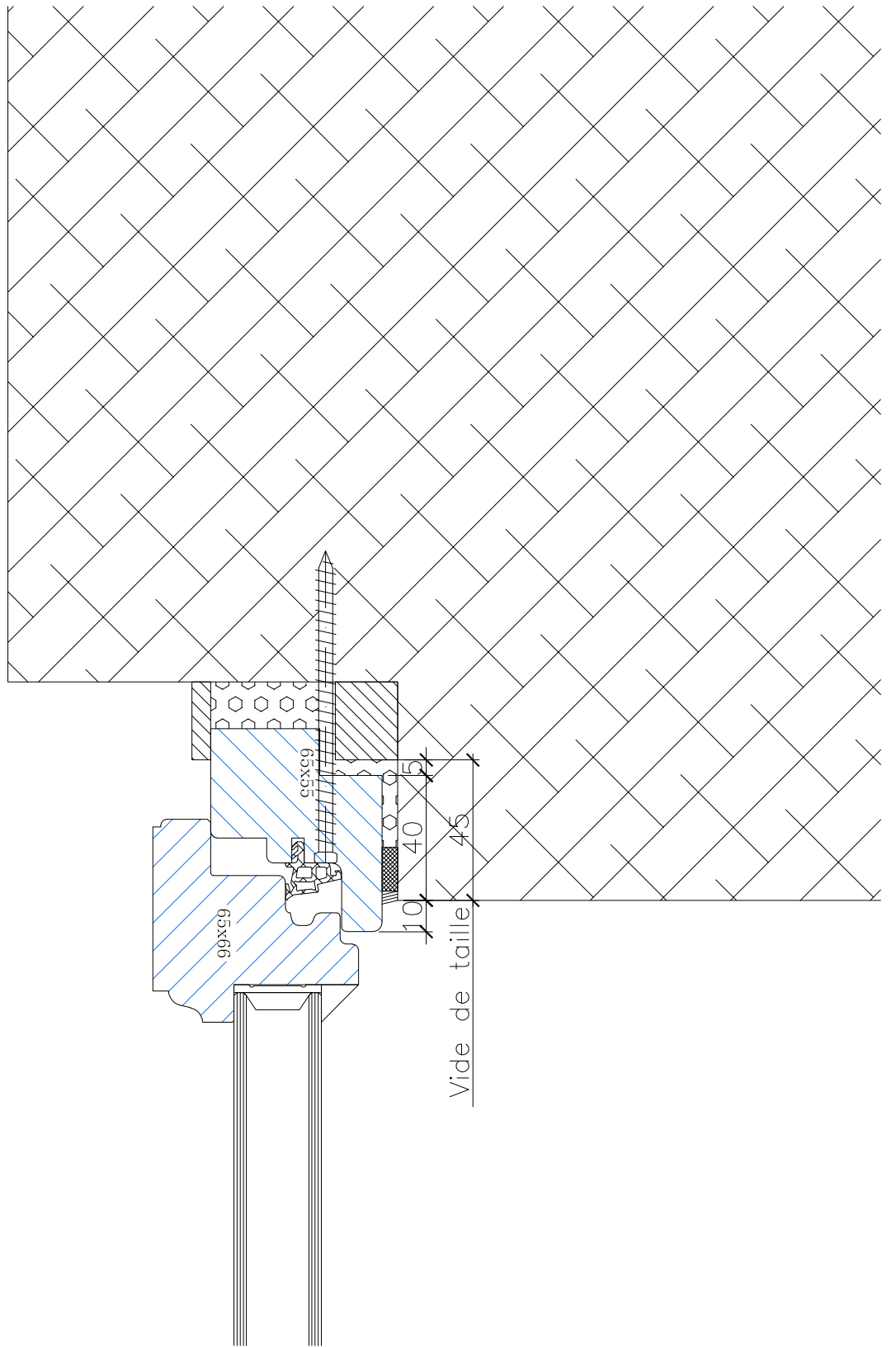

No	1	Date	31.05.2016
Tech.	SM	Mod.	19.10.2016
Ech.	1 : 2	Mod.	
Ech.	A 4	Mod.	

Article Fenêtre / partie haute

CAD
2002

Objet

Fenêtre bois à l'ancienne

POS.:

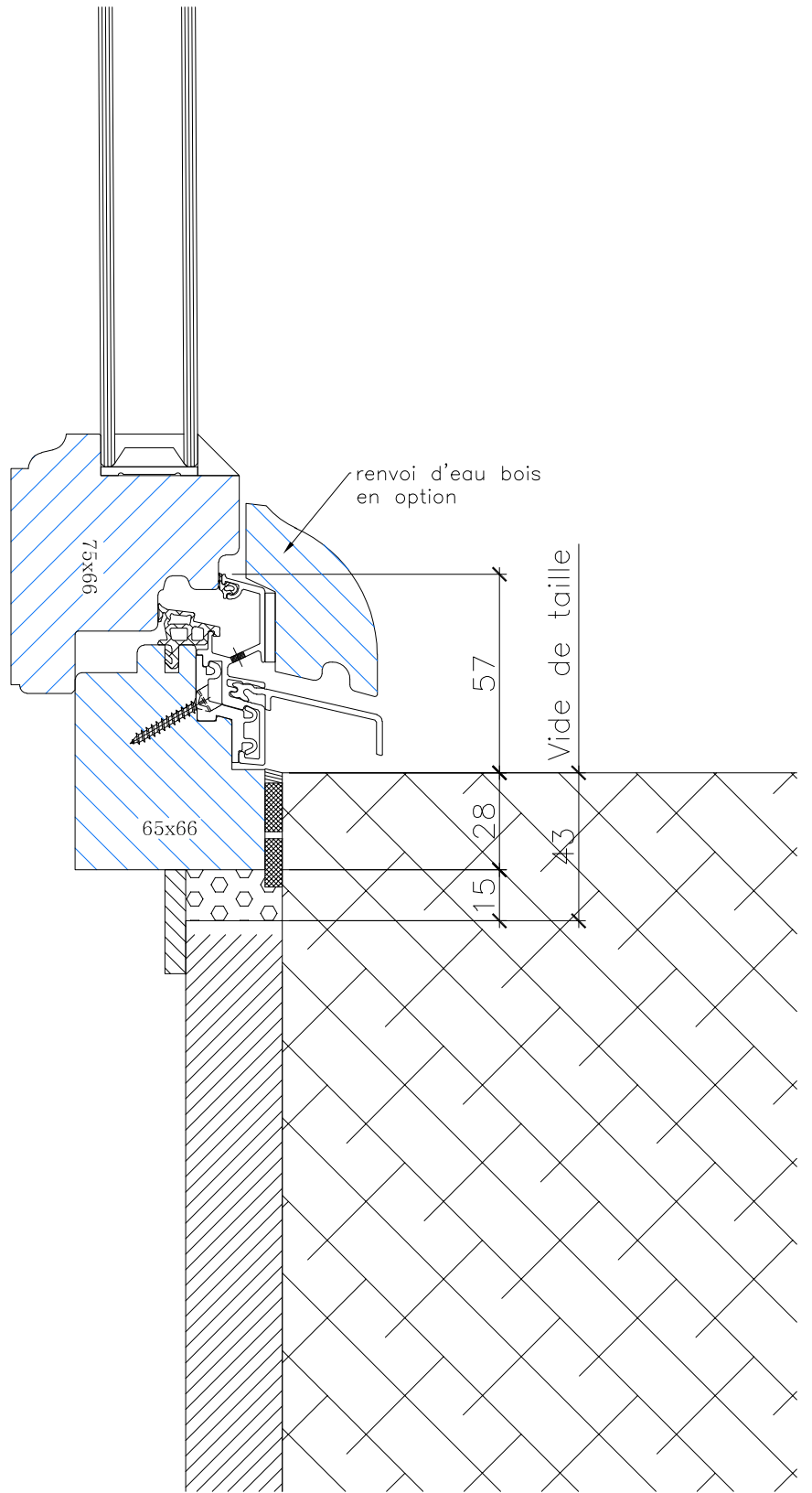

No	4	Date	31.05.2016
Tech.	SM	Mod.	19.10.2016
Ech.	1 : 2	Mod.	
Ech.	A 4	Mod.	

Article Fenêtre partie basse + renvoi d'eau bois

CAD
2017

Objet

Fenêtre bois à l'ancienne

POS.:

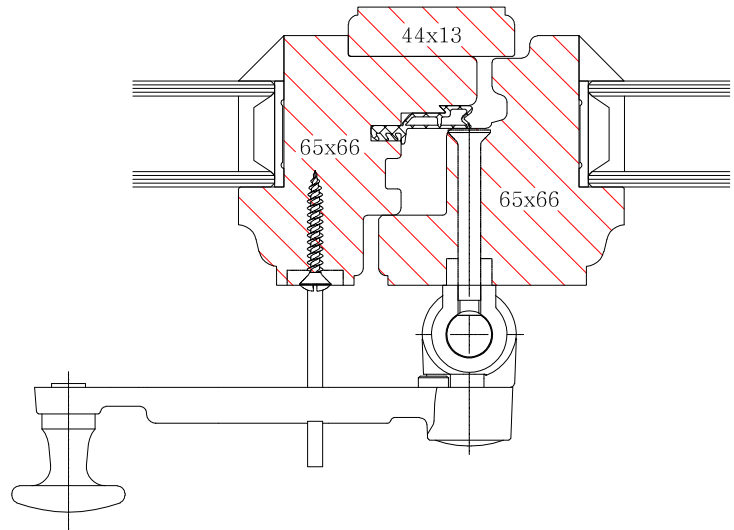
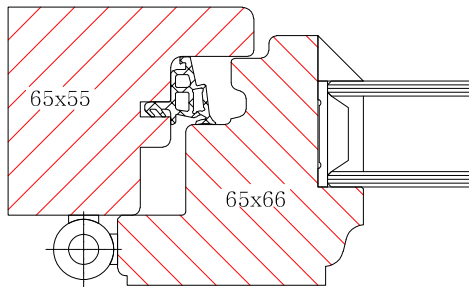
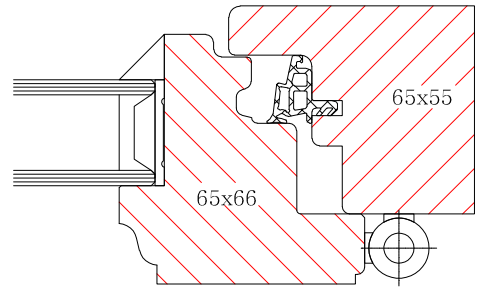
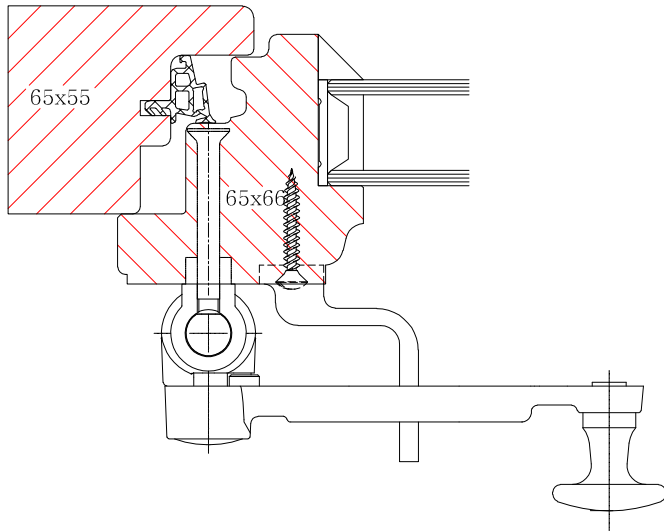

No	4	Date	31.05.2016
Tech.	SM	Mod.	19.10.2016
Ech.	1 : 2	Mod.	
Ech.	A 4	Mod.	

Article Espagnolette 1V, espagnolette 2V

CAD
2017

Objet

Fenêtre bois à l'ancienne

POS.:

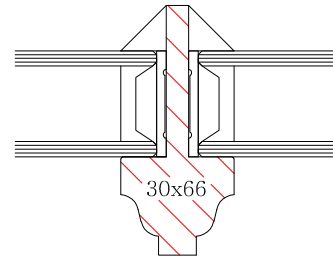
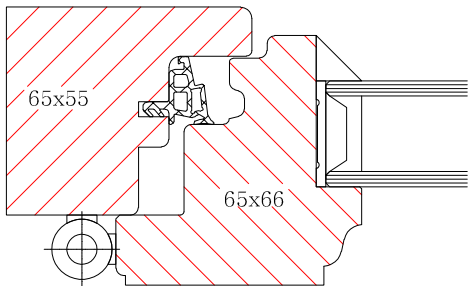
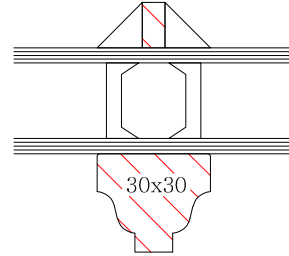
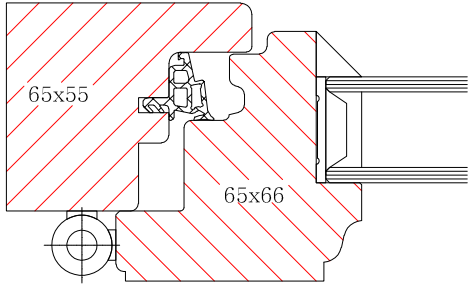

No	4	Date	31.05.2016
Tech.	SM	Mod.	19.10.2016
Ech.	1 : 2	Mod.	
Ech.	A 4	Mod.	

Article Petits bois collés, petits bois traversants

CAD
2017

Objet

Fenêtre bois à l'ancienne

POS.:

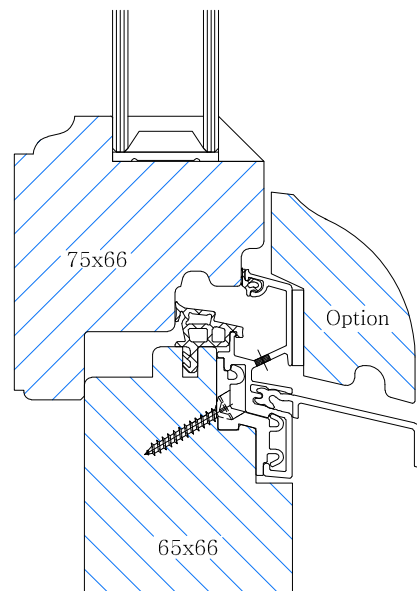
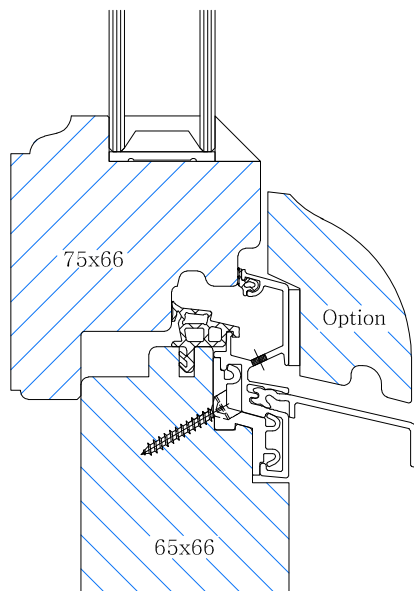
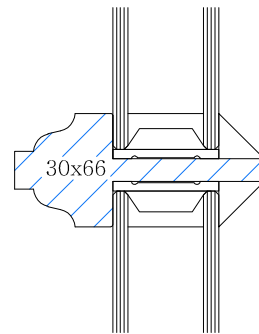
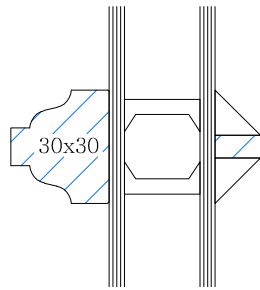
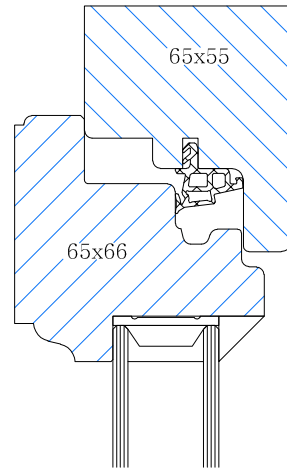
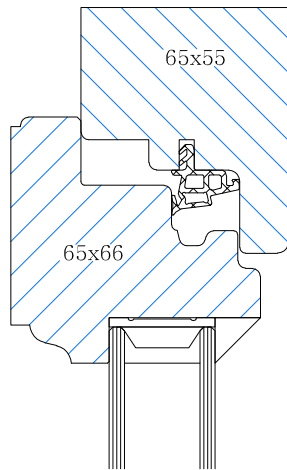

No	4	Date	31.05.2016
Tech.	SM	Mod.	19.10.2016
Ech.	1 : 2	Mod.	
Ech.	A 4	Mod.	

Article Petits bois collés, petits bois traversants

CAD 2017 Objet

Fenêtre bois à l'ancienne

POS.: